

ÜRÜN MONTAJ KLAVUZU

AURA GENÇ ODASI KOMODİN

**SATIŞ SONRASI HİZMET
DESTEK WHATSAPP HATTI**



MONTAJ HAZIRLIK: Tüm paketleri dikkatli bir şekilde açınız. Ürün parçalarını şekil ve boyutlarına göre sınıflandırınız.

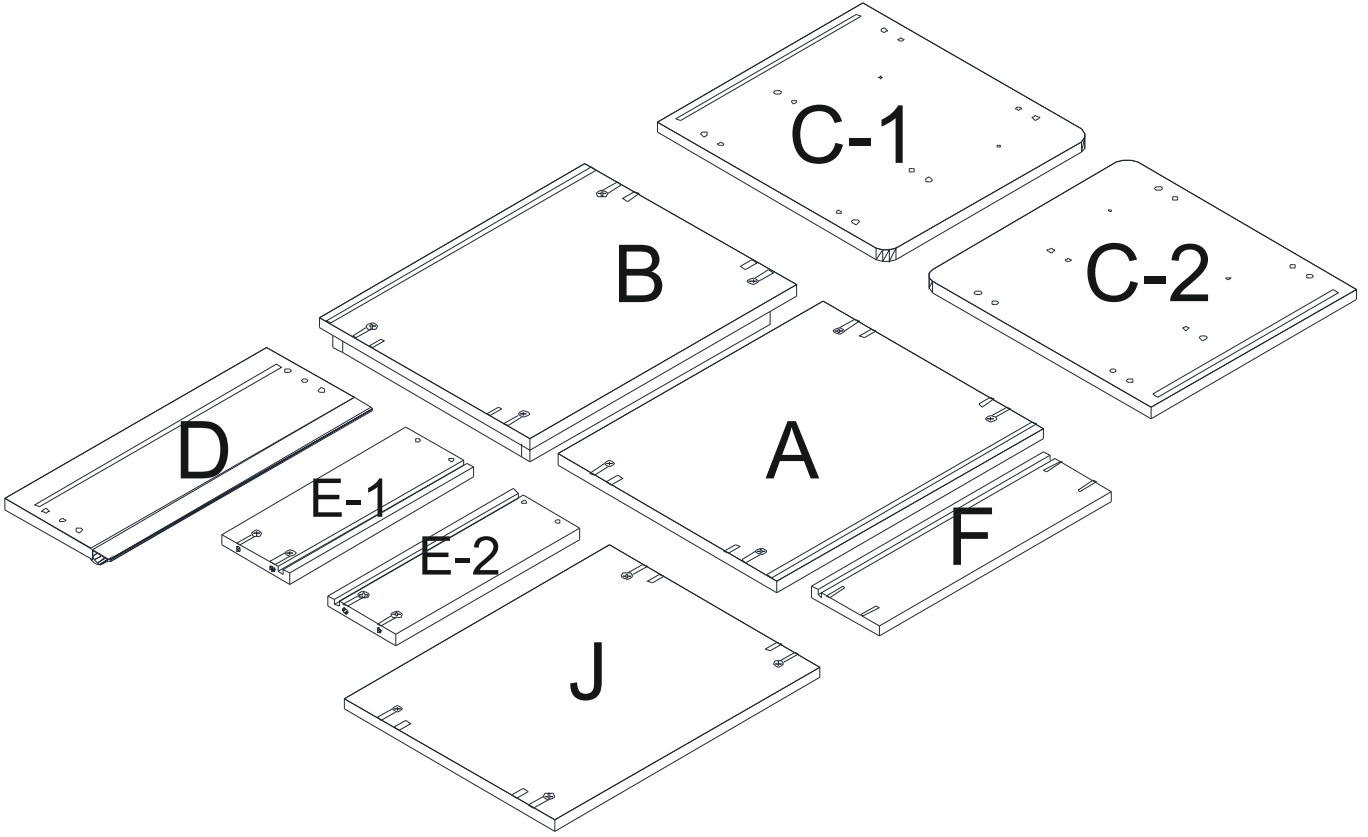

MONTAJ İÇİN GEREKLİ ALET ÖNERİLERİ: Şarjlı matkap, Yıldız başlı tornavida, Çekiç

- A: ÜST TABLA**
- B: ALT TABLA**
- C: SAĞ-SOL YAN TABLA**
- D: ÇEKMECE ÖN YÜZ**
- E: ÇEKMECE YANLAR**
- F: ÇEKMECE ARKA**
- J: ARA ÜST TABLA**

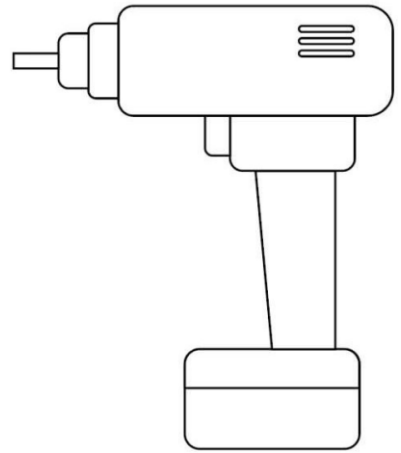
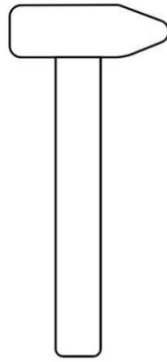

MONTAJ HAZIRLIK: MALZEME POŞET İÇERİĞİ

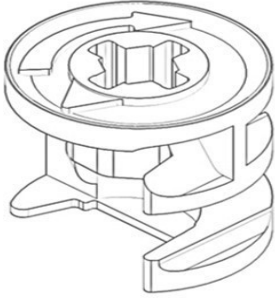

V01

16 ADET MİNİFİX
GÖVDE

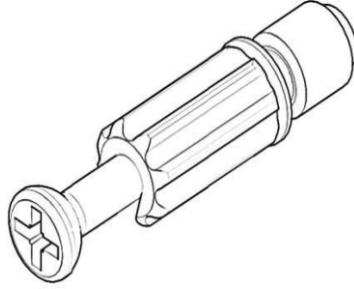

V02

16 ADET MİNİFİX
MİL

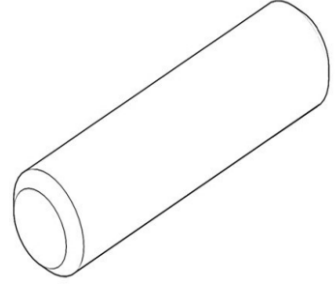

V03

14 ADET PLASTİK
SİYAH KAVELA

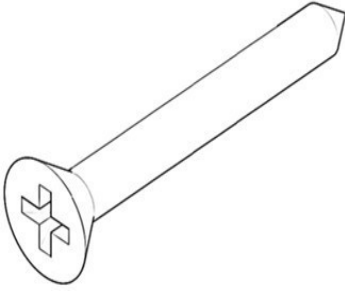

V04

4 ADET
KABİN VİDASI

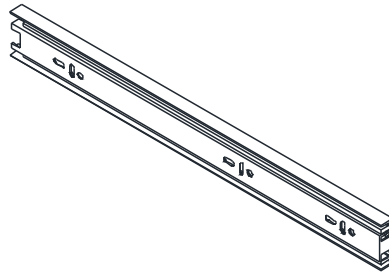

V05

1 TK
35 CM TELESKOBİK RAY

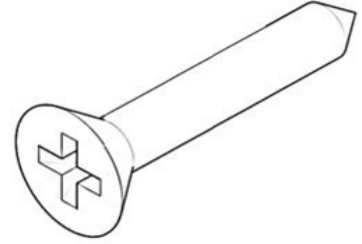

V06

6 ADET
3,5*18 VİDA

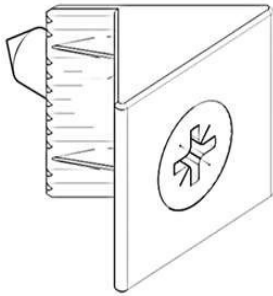

V07

3 ADET
ARKALIK SIKIŞTIRMA

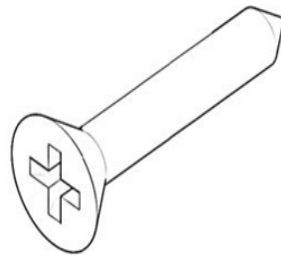

V08

3 ADET
3,5*25 ARKALIK VİDASI

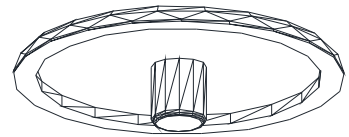

V09

16 ADET
MİNİFİX TIPASI

MONTAJ AŞAMALARI - 1

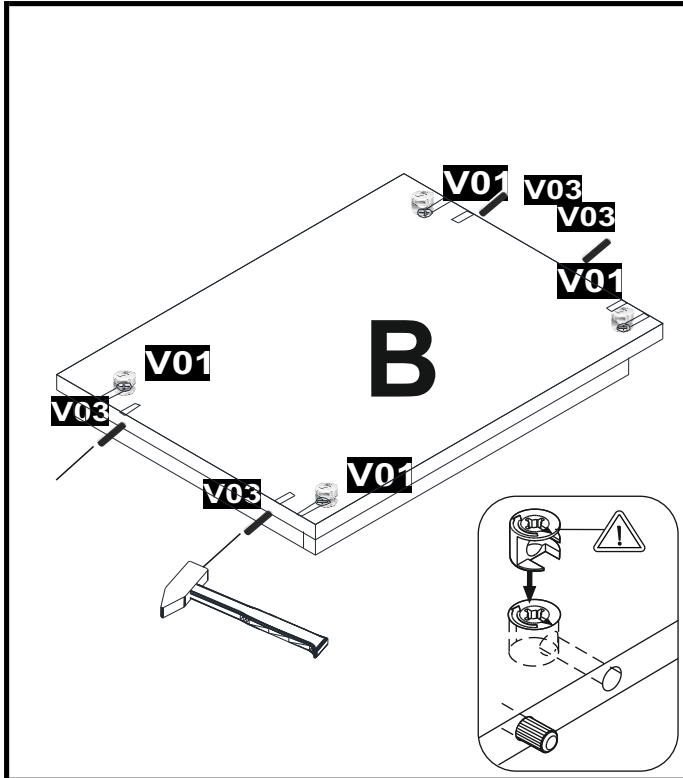

B PARÇASINDA (ALT TABLA) BULUNAN DELİKLERE ŞEKİLDE GÖRÜLDÜĞÜ GİBİ **V01,V03** KODLU MALZEMELERİ TAKINIZ.

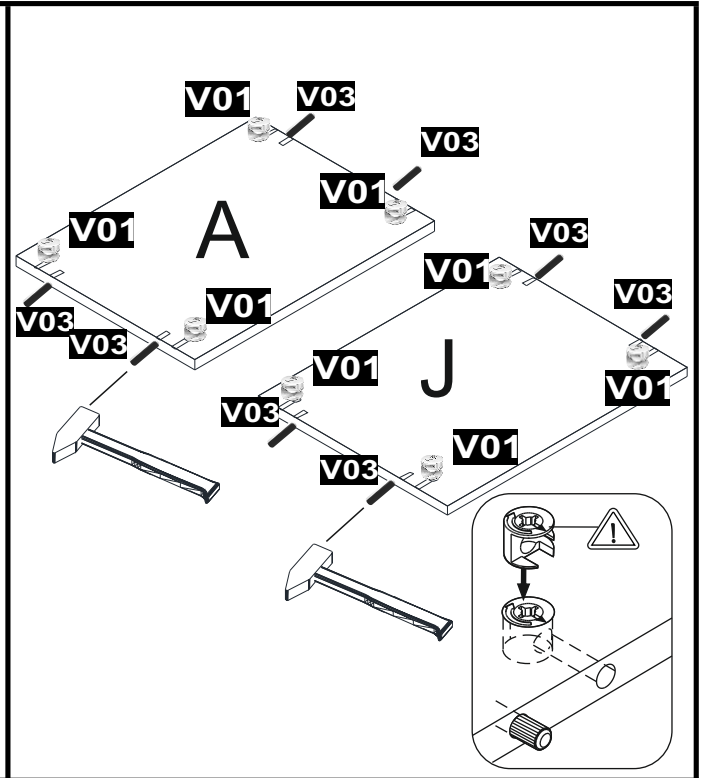

A VE **J** PARÇALARIN (ARA ÜST TABLA) BULUNAN DELİKLERE ŞEKİLDE GÖRÜLDÜĞÜ GİBİ **V01,V03** KODLU MALZEMELERİ TAKINIZ.

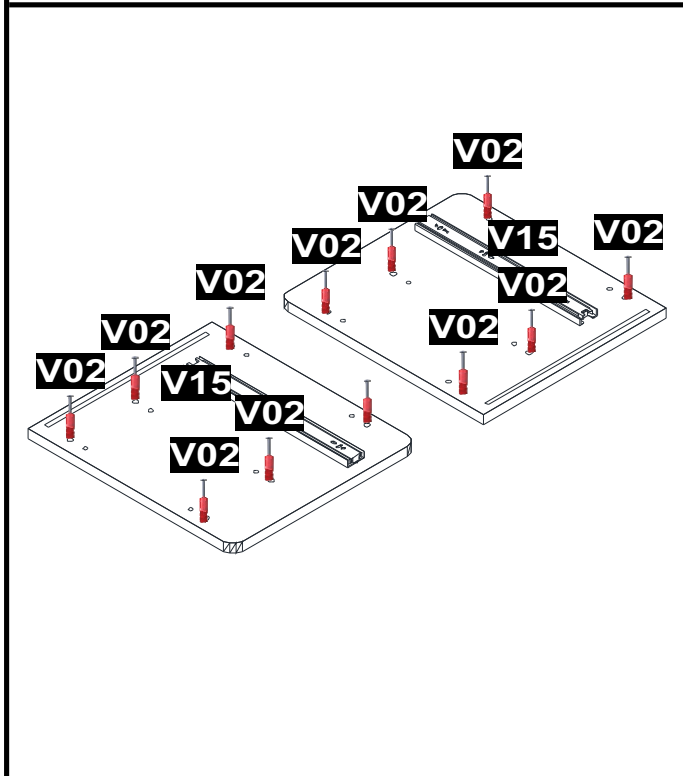

C-1 VE **C-2** PARÇALARI (SAĞ-SOL YAN TABLALAR) ÜZERİNDE BULUNAN DELİKLERE **V02,V15** KODLU MALZEMELERİ TAKINIZ. ARDINDAN YAN TABLA ÜZERİNDE BULUNAN VİDA İZLERİNDEN **V06** VİDALAR İLE RAYLARI BAĞLAYINIZ.

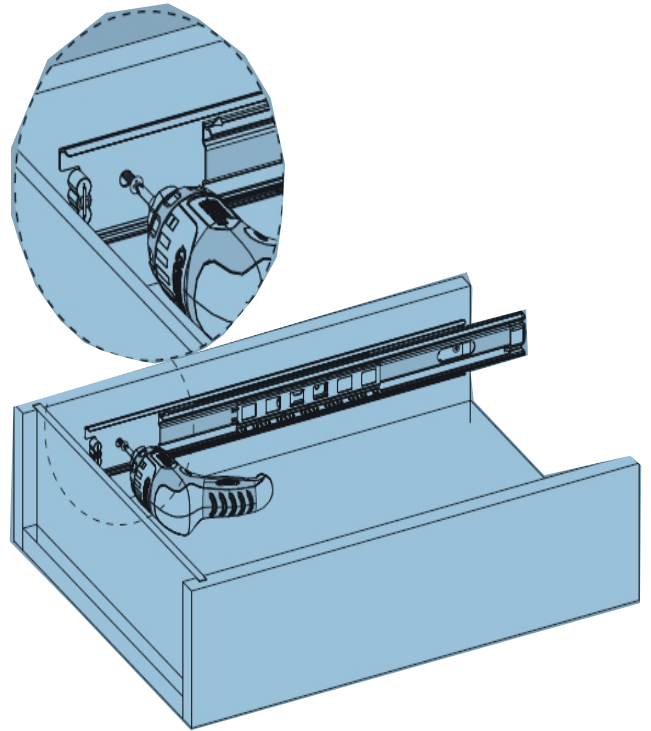

MODÜL YAN ÇEKMECE BAĞLAMA ŞEKLİ. **V06** KODLU MALZEME KULLANINIZ **3,5X18 VİDA**

MONTAJ AŞAMALARI - 2

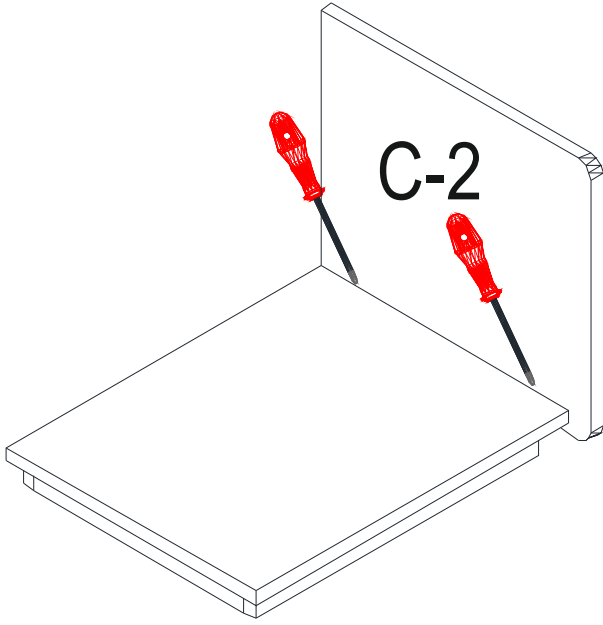

KOMİDİN İLK AŞAMASINDA SIRALAMA İLE BİRLİKTE BAŞLAYINIZ **B,C-2** KODLU PARÇALARIN TORNAVİDA YARDIMI MONTAJA BAŞLAYINIZ.

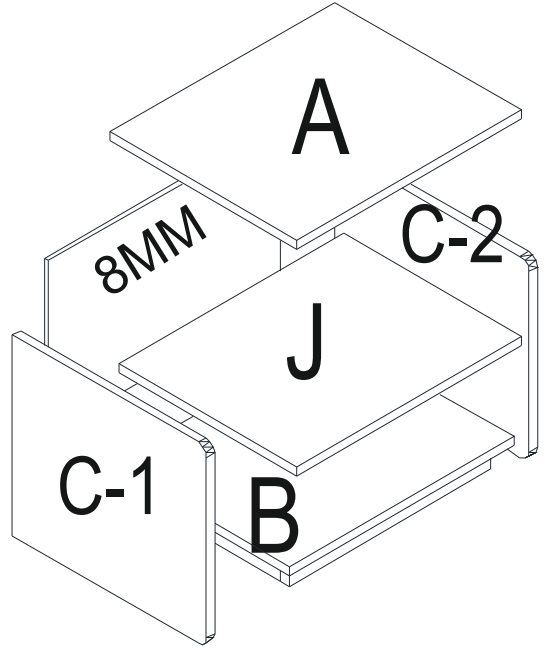

KOMİDİN MONTAJ ESNASINDA VERİLEN SIRALAMAYI **J,A,8MM,C-1** UYGULAYARAK MONTE EDİNİZ.

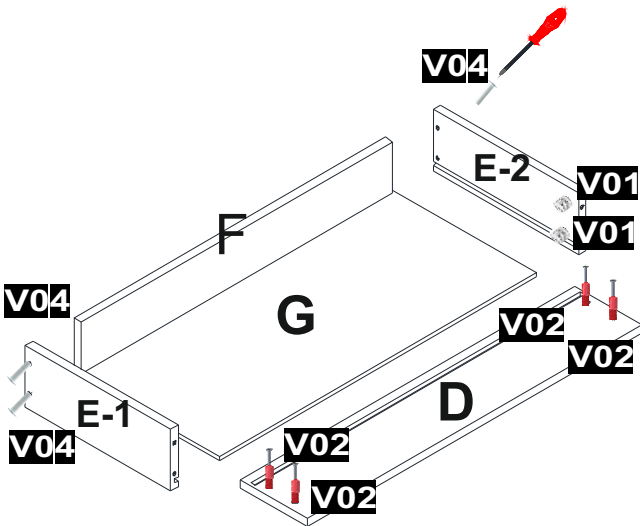

ŞEKİLDE GÖRÜLDÜĞÜ GİBİ **D** PARÇASINA **V02** KODLU MALZEMEYİ TAKINIZ. ARDINDAN **E-1 VE E-2** PARÇALARINI **D** PARÇASINA TAKINIZ. DAHA SONRA KANALLARDAN **G** PARÇASINI GEÇİRİNİZ. SON OLARAK **F** PARÇASINI **V04** KODLU MALZEMELER İLE BİRLEŞTİRİNİZ.

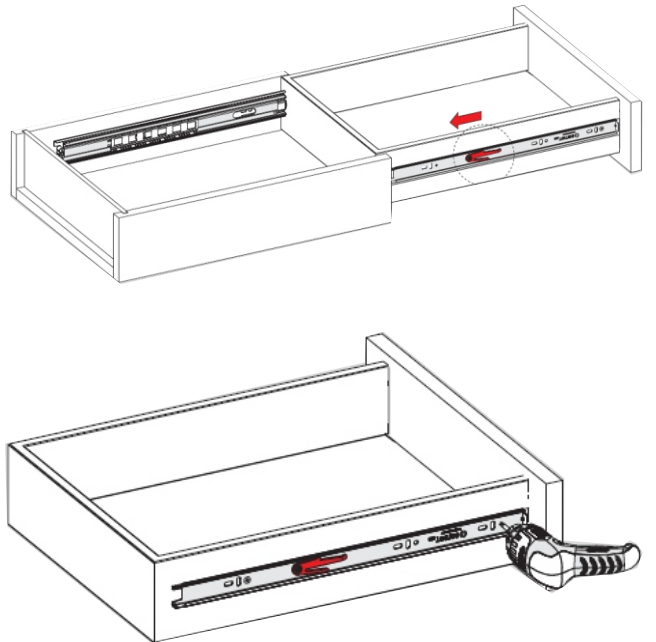

ÇEKMECE YANINA DIŞTAN TAM MERKEZE GELECEK ŞEKİLDE **V06** KODU VİDA YARDIMI İLE BAŞTAN SIFIR OLACAK ŞEKİLDE SIKINIZ

MONTAJ AŐAMALARI - 3

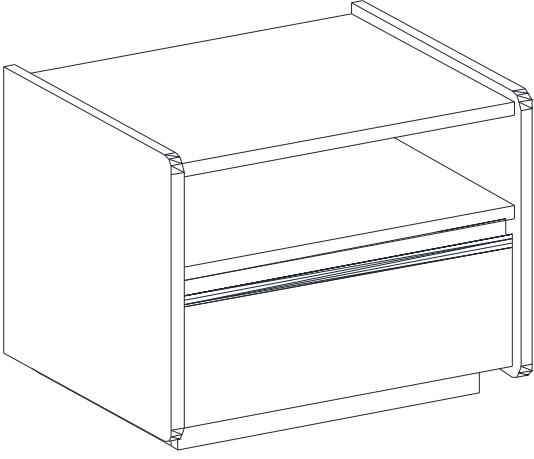

KOMODİN MONTAJI BİTİRİLMİŐ GÖRSELİ.