

# ÜRÜN MONTAJ KLAVUZU

## GİZE GENÇ ODASI KOMİDİN

**SATIŞ SONRASI HİZMET  
DESTEK WHATSAPP HATTI**



**MONTAJ HAZIRLIK:** Tüm paketleri dikkatli bir şekilde açınız. Ürün parçalarını şekil ve boyutlarına göre sınıflandırınız.

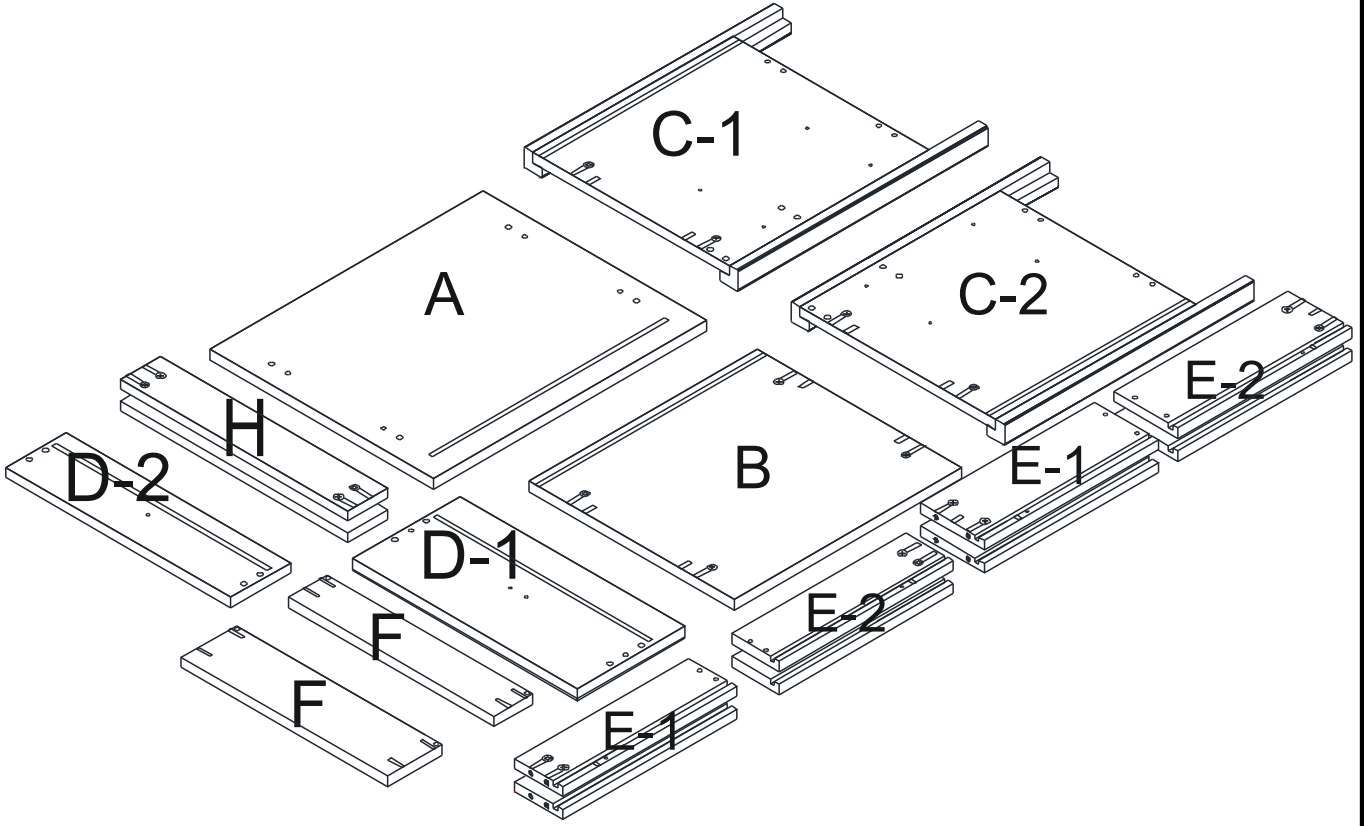

**MONTAJ İÇİN GEREKLİ ALET ÖNERİLERİ:** Şarjlı matkap, Yıldız başlı tornavida, Çekiç

- A: ÜST TABLA**
- B: ALT TABLA**
- C: SAĞ-SOL YAN**
- D: ÇEKMECE ÖN**
- F: ÇEKMECE ARKA**
- G: ÇEKMECE DİBİ**
- H: ARA KLAPA**
- E: SAĞ SOL ÇEKMECE YAN**

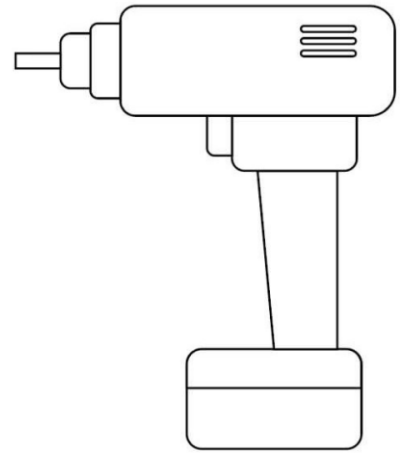
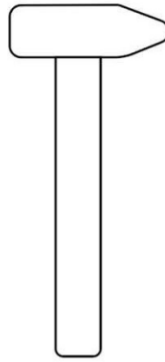

# MONTAJ HAZIRLIK: MALZEME POŞET İÇERİĞİ

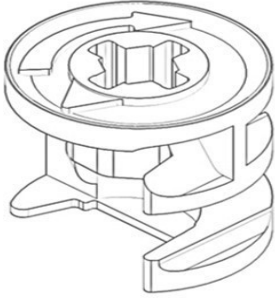

**V01**

24 ADET MİNİFİX  
GÖVDE

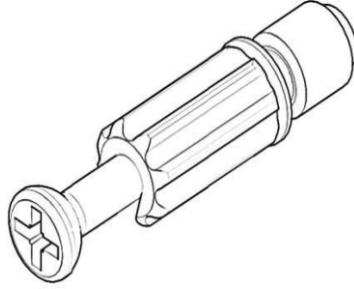

**V02**

24 ADET MİNİFİX  
MİL

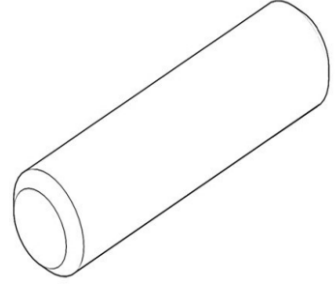

**V03**

12 ADET PLASTİK  
SİYAH KAVELA

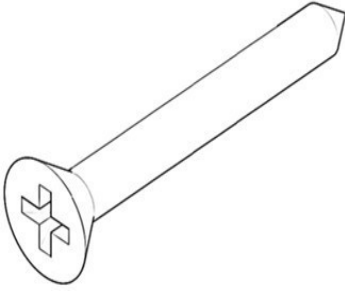

**V04**

8 ADET  
KABİN VİDASI

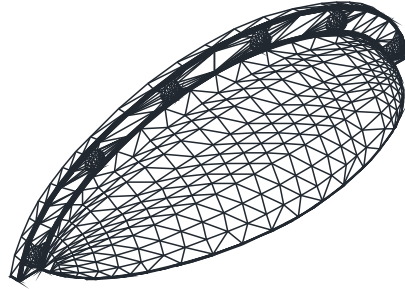

**V05**

1 ADET  
ÇANAK KULP

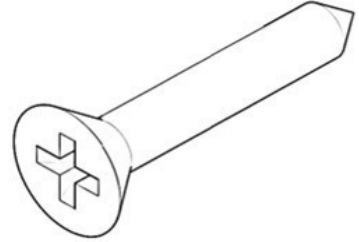

**V06**

10 ADET  
3,5X18 VİDA

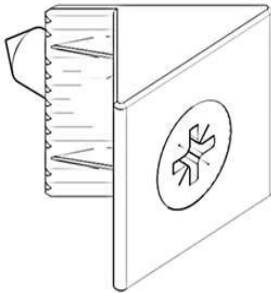

**V07**

3 ADET  
ARKALIK SIKTIRMA

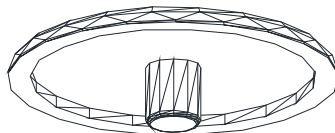

**V08**

24 ADET  
MİNİFİX TIPASI

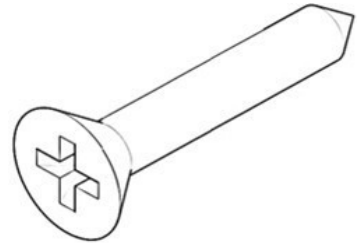

**V09**

3 ADET  
3,5\*25 ARKALIK VİDAS

# MONTAJ HAZIRLIK: MALZEME POŞET İÇERİĞİ

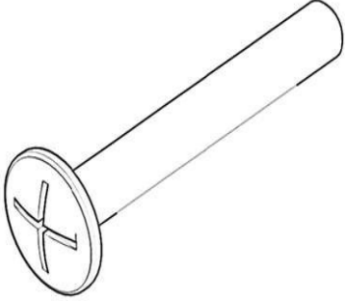

**V10**

3 ADET  
22 KULP VİDASI

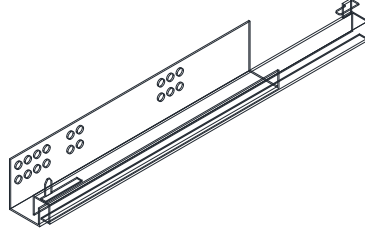

**V11**

2 TK  
35 CM FRENLİ RAY

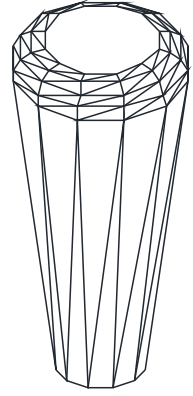

**V12**

1 ADET  
TEKLİ KULP

**V13**

**V14**

**V15**

**V16**

**V17**

**V18**

# MONTAJ AŞAMALARI - 1

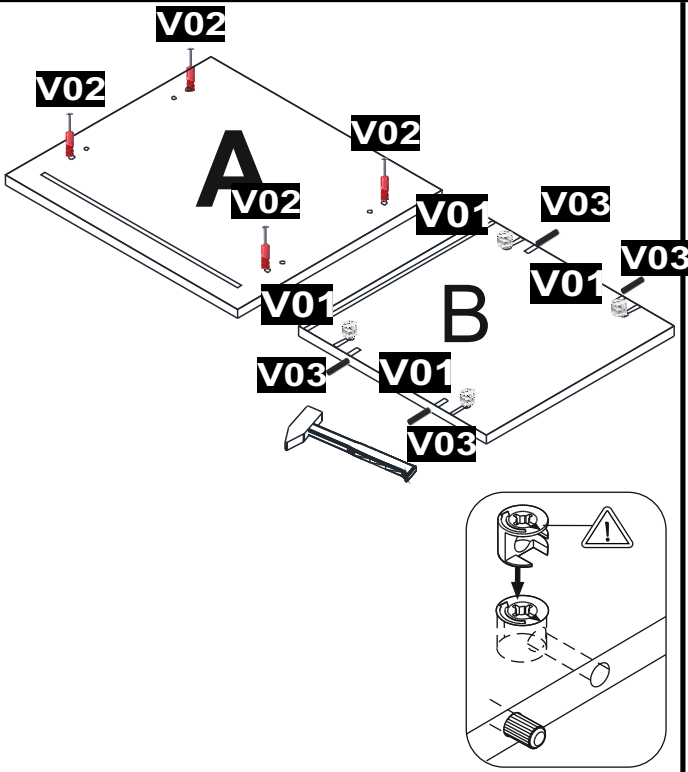

**A.B** PARÇASINDA (ALT ÜSTTABLA) BULUNAN DELİKLERE ŞEKİLDE GÖRÜLDÜĞÜ GİBİ **V01,V02** **.V03** KODLU MALZEMELERİ TAKINIZ.

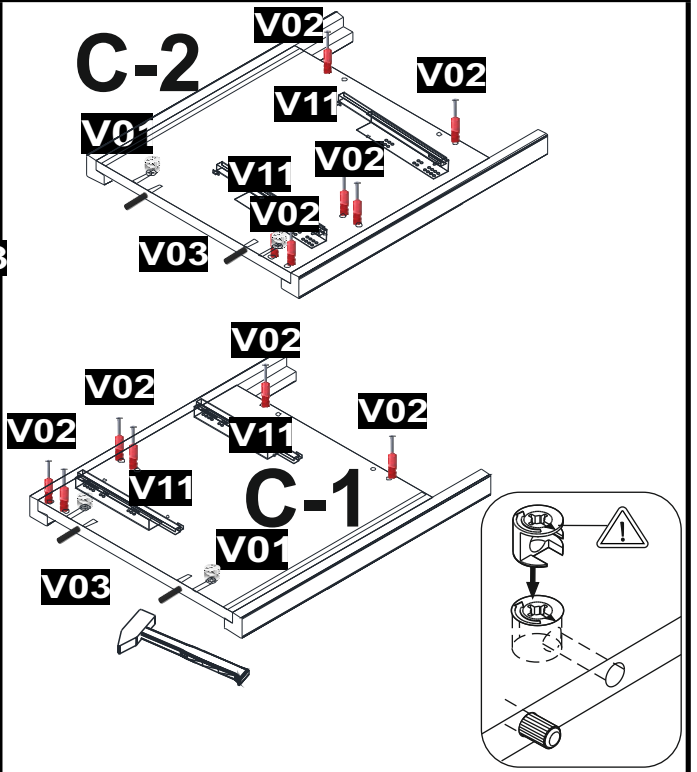

**C-1** VE **C-2** PARÇALARI (SAĞ-SOL YAN TABLALAR) ÜZERİNDE BULUNAN DELİKLERE **V01,V02,V03,V11** KOD BULUNAN MALZEMELERİ TAKINIZ.

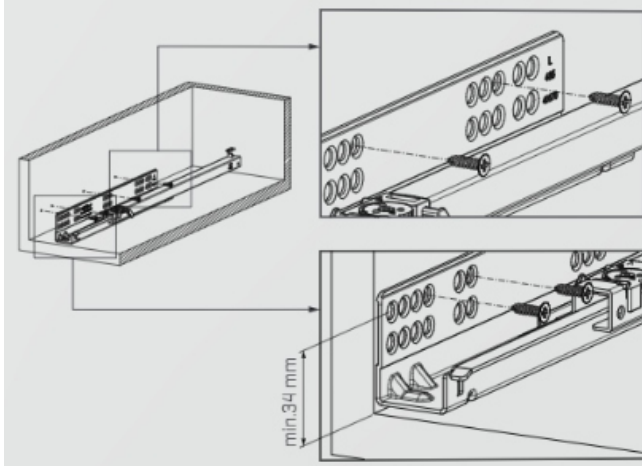

260 mm

285-310-335

360-385-410 mm



**V15** KODLU MALZEME (FRENLİ RAY) BAĞLANTI KLAVUZU.

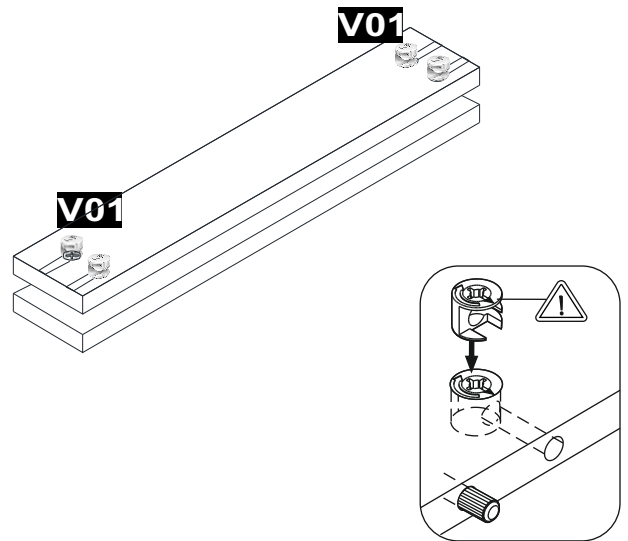

**H** KODLU PARÇANIN **V01** GÖRE MALZEMELERİ TAKINIZ.

# MONTAJ AŐAMALARI - 2

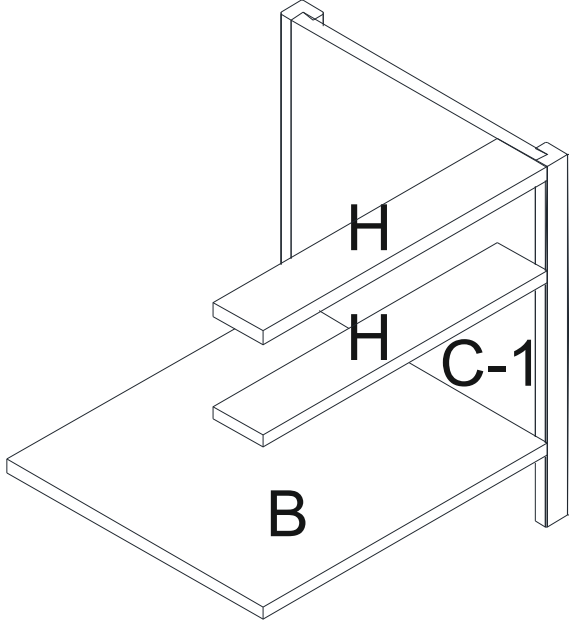

KOMİDİN ŐEKİLDE GÖRÜLDÜĐÜ GİBİ **C-1,B,H** PARÇALARI TOPLAMAYA BAŐLAYINIZ

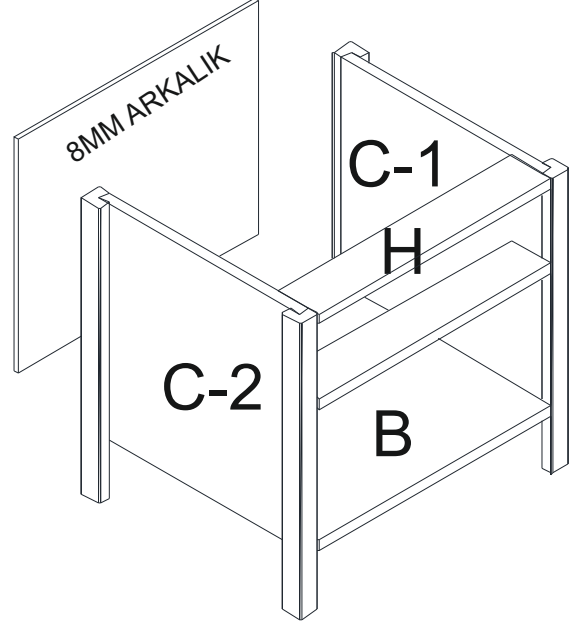

KOMİDİN ŐEKİLDE GÖRÜLDÜĐÜ GİBİ **C-2** YANI VE 8 MM ARKALIĐI TAKINIZ

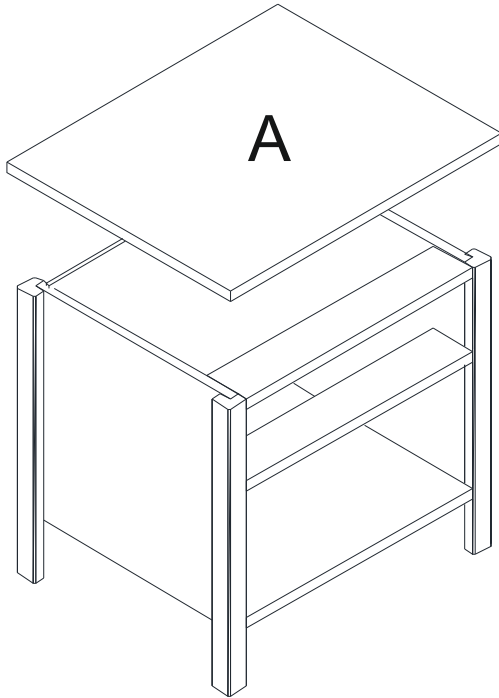

KOMİDİN **A** KODLU (ÜST TABLAYI) TAKINIZ.

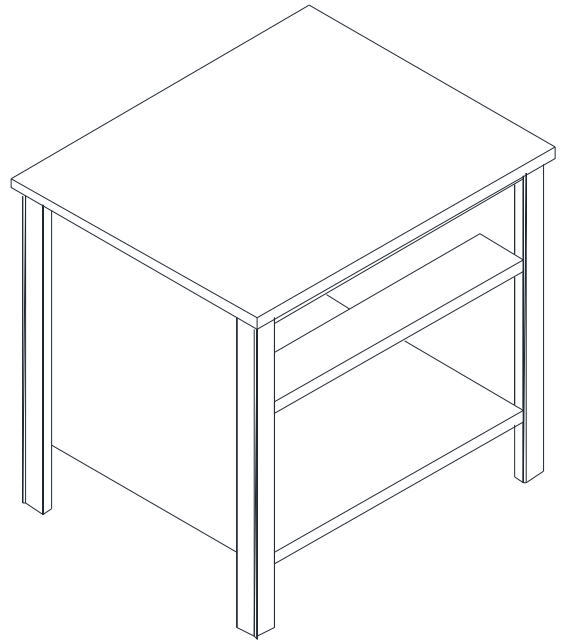

KOMİDİN TOPLANMIŐ HALİ

# MONTAJ AŞAMALARI - 3

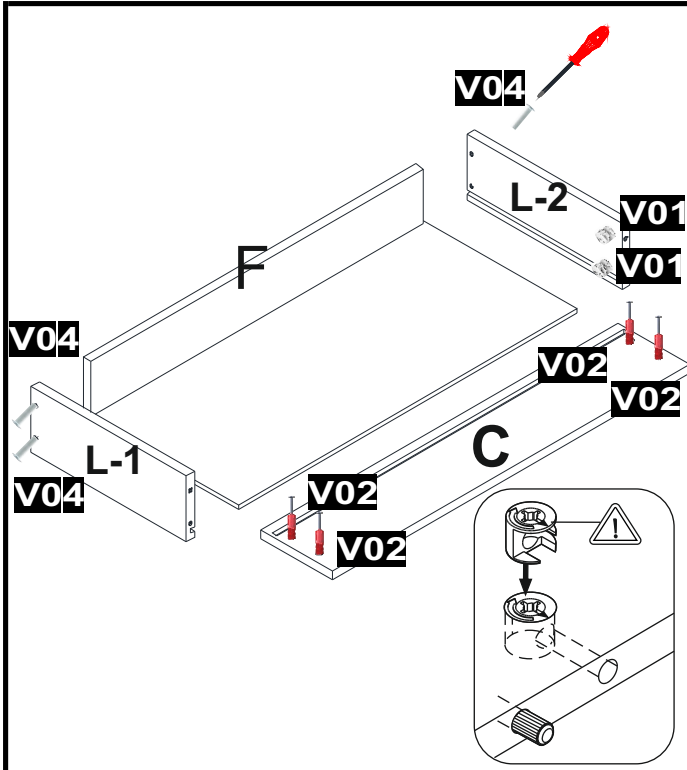

ŞEKİLDE GÖRÜLDÜĞÜ GİBİ **C** PARÇASINA **V02** KODLU MALZEMEYİ TAKINIZ. ARDINDAN **L-1 VE L-2** PARÇALARINI **C** PARÇASINA TAKINIZ. DAHA SONRA KANALLARDAN ARKALIK PARÇASINI GEÇİRİNİZ. SON OLARAK **F** PARÇASINI **V04** KODLU MALZEMELER İLE BİRLEŞTİRİNİZ.

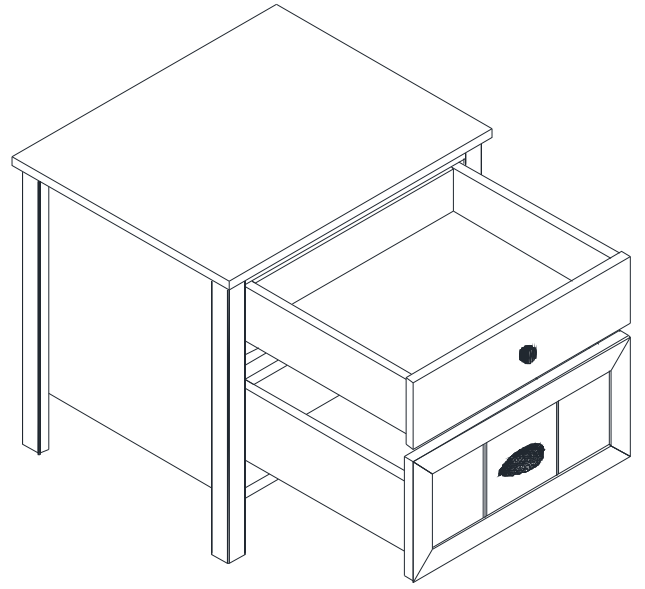

KOMİDİN ÇEKMECELERİ SOLDAKİ ŞEMAYA GÖRE TAKINIZ.

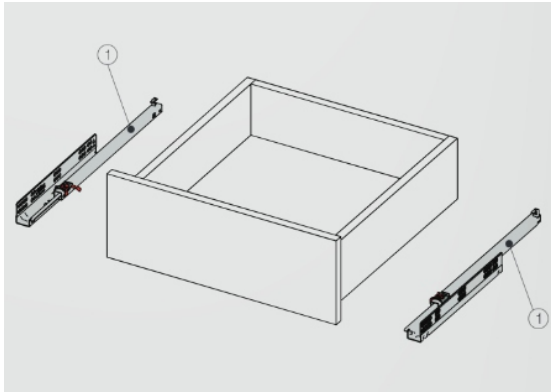
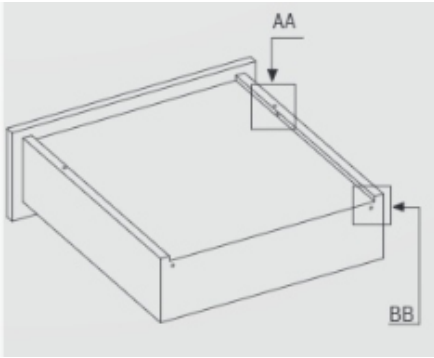

ÇEKMECE KUTULARI OLUŞTURULDUKTAN SONRA RAY PİMLERİ 1. ŞEKİLDE GÖSTERİLEN DELİKLERE DENK GELECEK ŞEKİLDE 2. RESİM TUTUŞ POZİSYONUNDA RAYLARA YERLEŞTİRİNİZ VE ALT KISIMDAKİ PİMLERİ KİLİTLEYİNİZ.

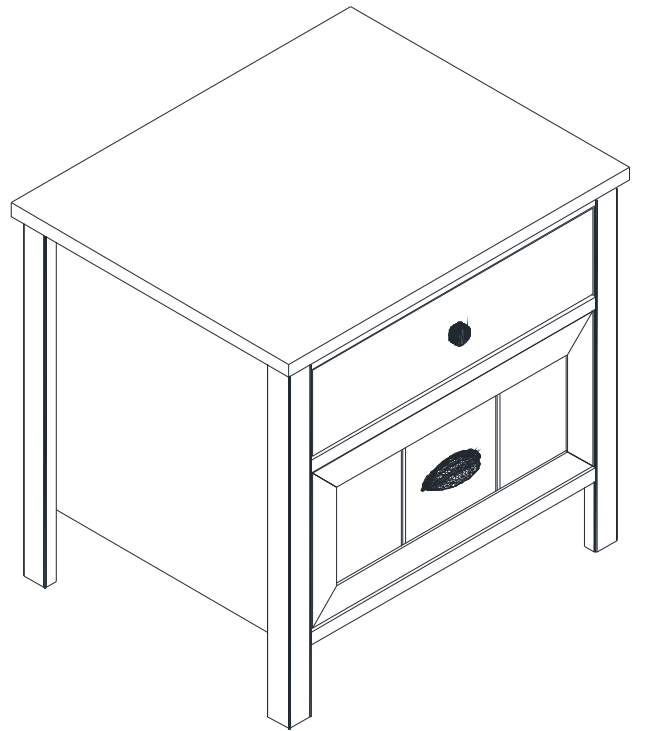

MODÜLÜN BİTMİŞ HALİ.