

# ÜRÜN MONTAJ KLAVUZU

## HALİKARNAS GENÇ ODASI KOMODİN

**SATIŞ SONRASI HİZMET  
DESTEK WHATSAPP HATTI**



**MONTAJ HAZIRLIK:** Tüm paketleri dikkatli bir şekilde açınız. Ürün parçalarını şekil ve boyutlarına göre sınıflandırınız.

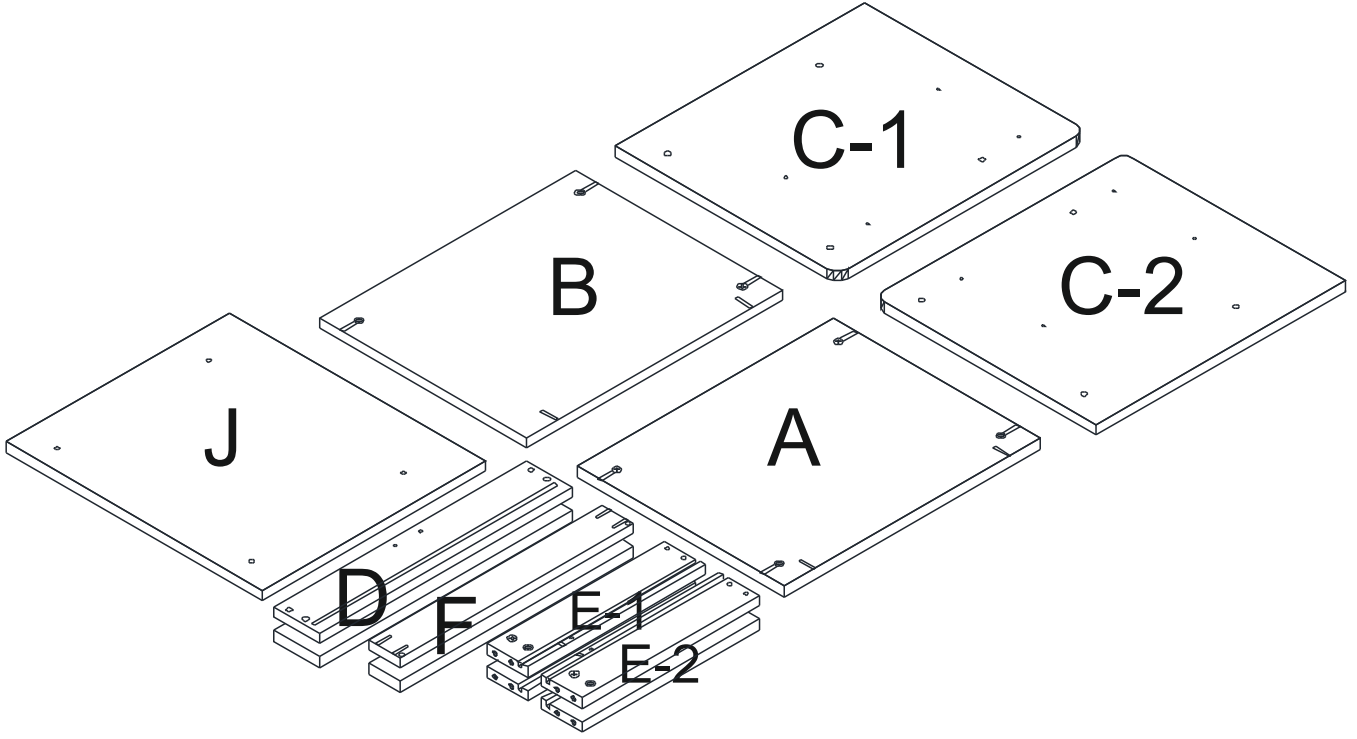

**MONTAJ İÇİN GEREKLİ ALET ÖNERİLERİ:** Şarjlı matkap, Yıldız başlı tornavida, Çekiç

- A: ÜST TABLA**
- B: ALT TABLA**
- C: SAĞ-SOL YAN TABLA**
- D: ÇEKMECE ÖN YÜZ**
- E: ÇEKMECE YANLAR**
- F: ÇEKMECE ARKA**
- J: ARKA PANO**

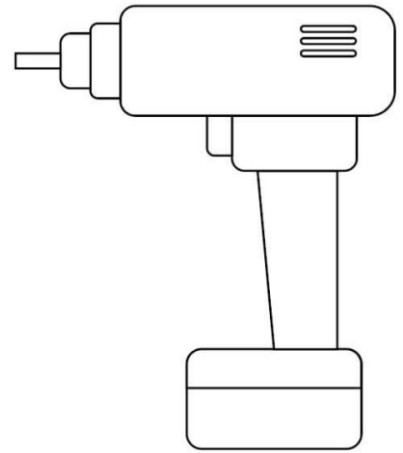
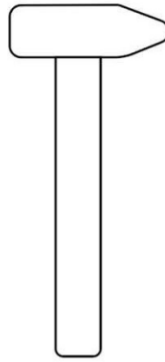

# MONTAJ HAZIRLIK: MALZEME POŞET İÇERİĞİ

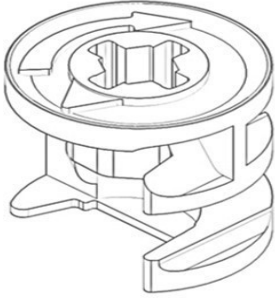

**V01**

16 ADET MİNİFİX  
GÖVDE

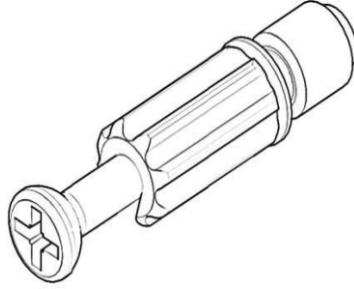

**V02**

16 ADET MİNİFİX  
MİL

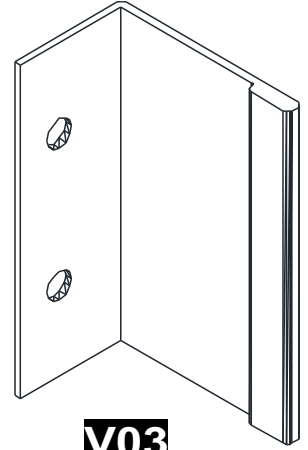

**V03**

2 ADET  
METAL BEYAZ KULP

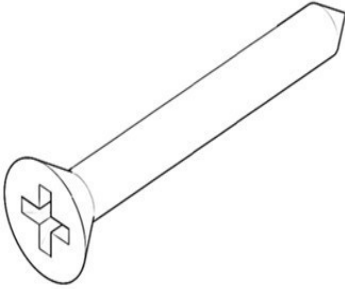

**V04**

12 ADET  
KABİN VİDASI

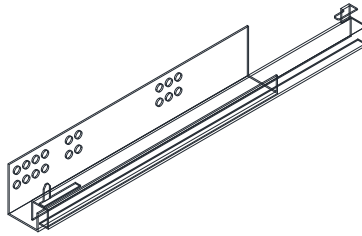

**V05**

2 TAKIM  
350 MM TANDEM RAY

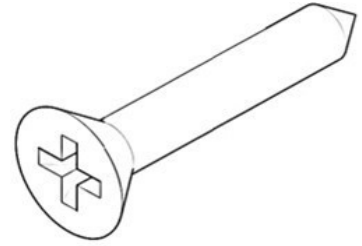

**V06**

12 ADET  
4\*18 VİDA

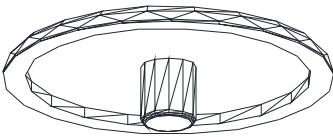

**V07**

16 ADET  
MİNİFİX TIPASI

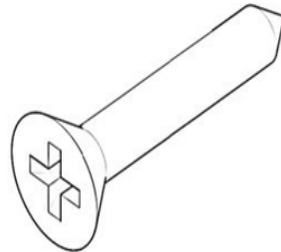

**V08**

4 ADET  
3,5\*25 ARKALIK VİDASI

**V09**

# MONTAJ AŞAMALARI - 1

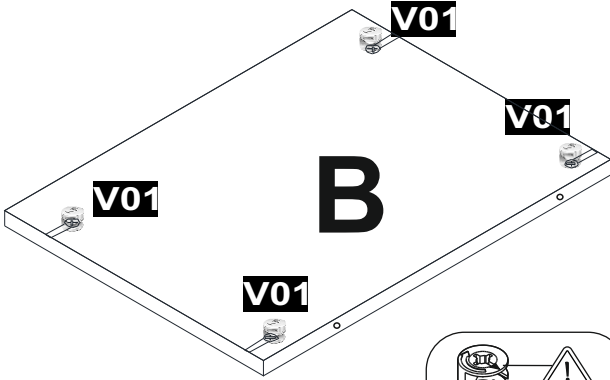

**B** PARÇASINDA (ALT TABLA) BULUNAN DELİKLERE ŞEKİLDE GÖRÜLDÜĞÜ GİBİ **V01** KODLU MALZEMELERİ TAKINIZ.

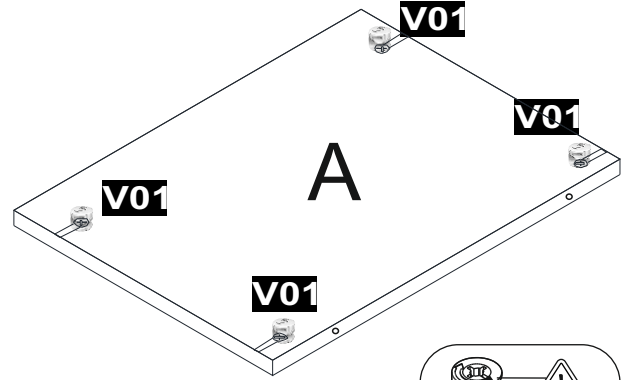

**A** PARÇASININ ( ÜST TABLA) BULUNAN DELİKLERE ŞEKİLDE GÖRÜLDÜĞÜ GİBİ **V01** KODLU MALZEMELERİ TAKINIZ.

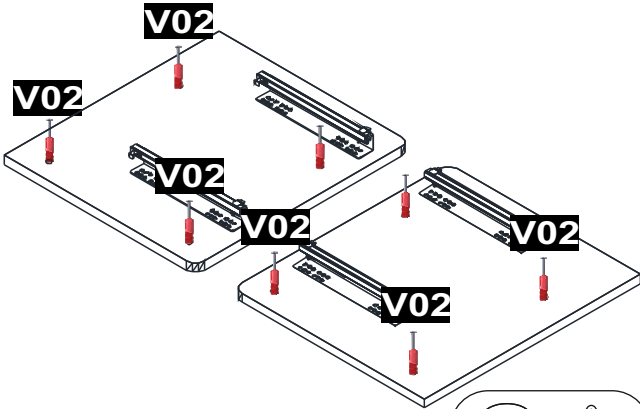

**C-1** VE **C-2** PARÇALARI (SAĞ-SOL YAN TABLALAR) ÜZERİNDE BULUNAN DELİKLERE **V02,V05** KODLU MALZEMELERİ TAKINIZ. ARDINDAN YAN TABLA ÜZERİNDE BULUNAN VİDA İZLERİNDEN **V06** VİDALAR İLE RAYLARI BAĞLAYINIZ.

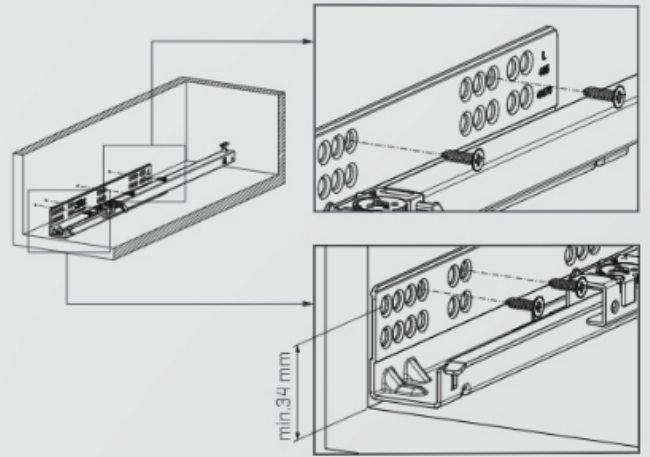

260 mm

285-310-335  
360-385-410 mm



**V05** KODLU MALZEME (FRENLİ RAY) BAĞLANTI KLVUZU.

# MONTAJ AŞAMALARI - 2

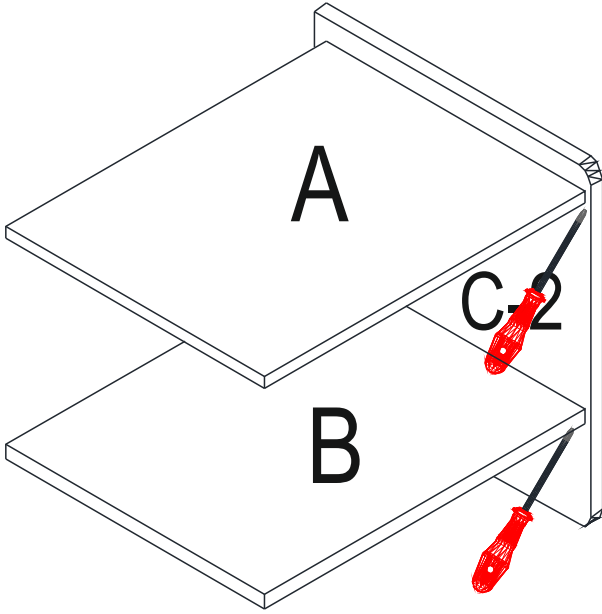

KOMİDİN İLK AŞAMASINDA SIRALAMA İLE BİRLİKTE BAŞLAYINIZ **B,C-2,A** KODLU PARÇALARIN TORNAVİDA YARDIMI MONTAJA BAŞLAYINIZ.

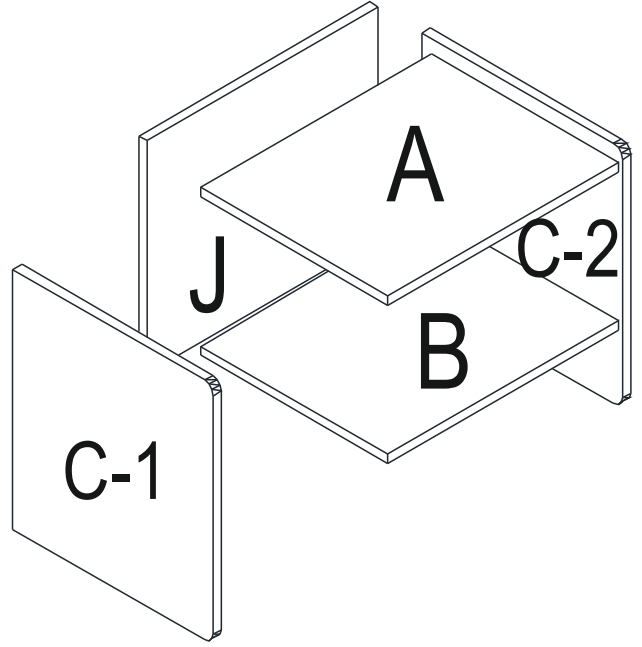

KOMİDİN MONTAJ ESNASINDA VERİLEN SIRALAMAYI **J,C-1** UYGULAYARAK MONTE EDİNİZ.

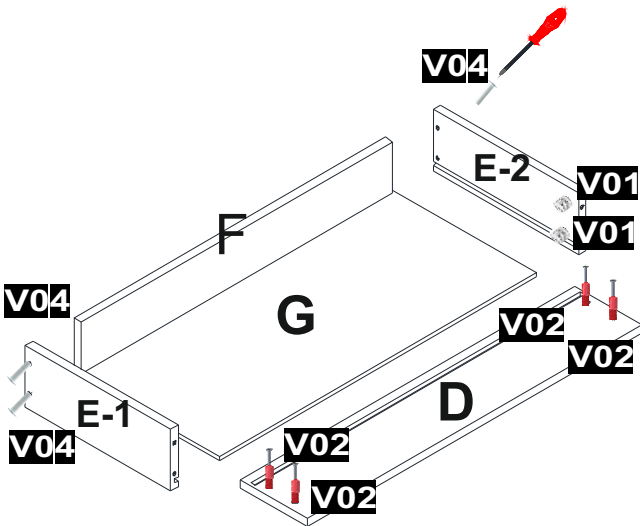

ŞEKİLDE GÖRÜLDÜĞÜ GİBİ **D** PARÇASINA **V02** KODLU MALZEMEYİ TAKINIZ. ARDINDAN **E-1 VE E-2** PARÇALARINI **D** PARÇASINA TAKINIZ. DAHA SONRA KANALLARDAN **G** PARÇASINI GEÇİRİNİZ. SON OLARAK **F** PARÇASINI **V04** KODLU MALZEMELER İLE BİRLEŞTİRİNİZ.

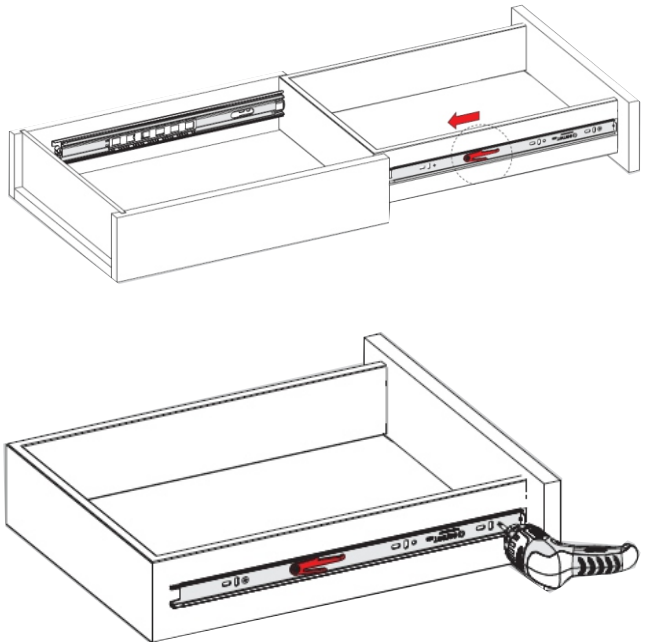

ÇEKMECE YANINA DIŞTAN TAM MERKEZE GELECEK ŞEKİLDE **V06** KODU VİDA YARDIMI İLE BAŞTAN SIFIR OLACAK ŞEKİLDE SIKINIZ

# MONTAJ AŞAMALARI - 3

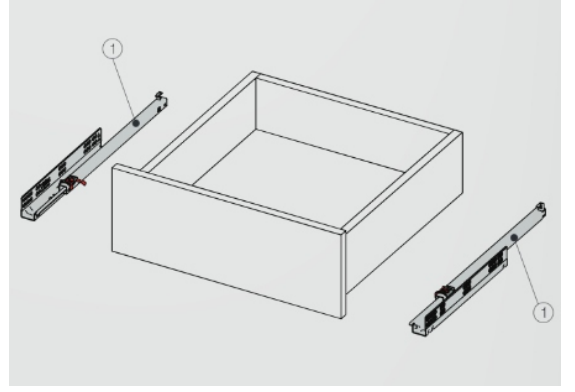
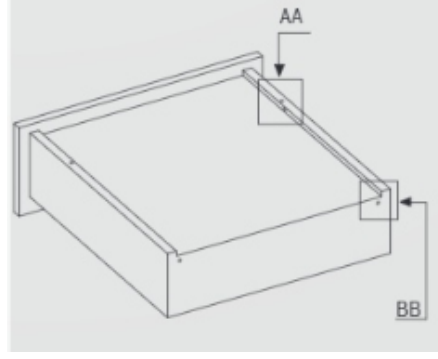
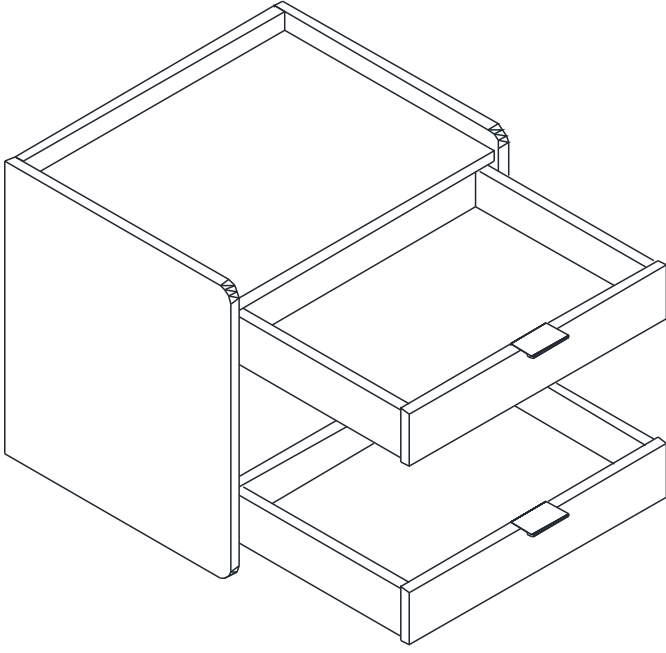

. ÇEKMECE KUTULARI OLUŞTURULDUKTAN SONRA RAY PİMLERİ 1. ŞEKİLDE GÖSTERİLEN DELİKLERE DENK GELECEK ŞEKİLDE 2. RESİM TUTUŞ POZİSYONUNDA RAYLARA YERLEŞTİRİNİZ VE ALT KISIMDAKİ PİMLERİ KİLİTLEYİNİZ.

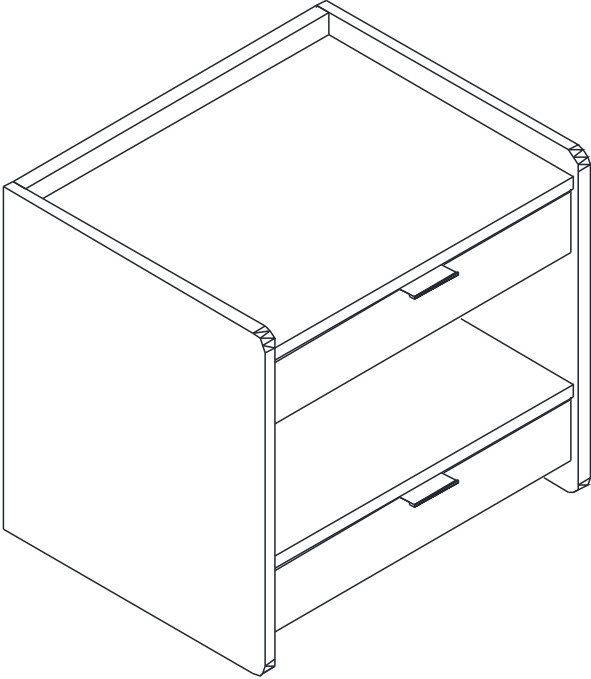

MODÜLÜN BİTMİŞ HALİ.