

ÜRÜN MONTAJ KLAVUZU

KEOS GENÇ ODASI ŞİFONYER

**SATIŞ SONRASI HİZMET
DESTEK WHATSAPP HATTI**



MONTAJ HAZIRLIK: Tüm paketleri dikkatli bir şekilde açınız. Ürün parçalarını şekil ve boyutlarına göre sınıflandırınız.

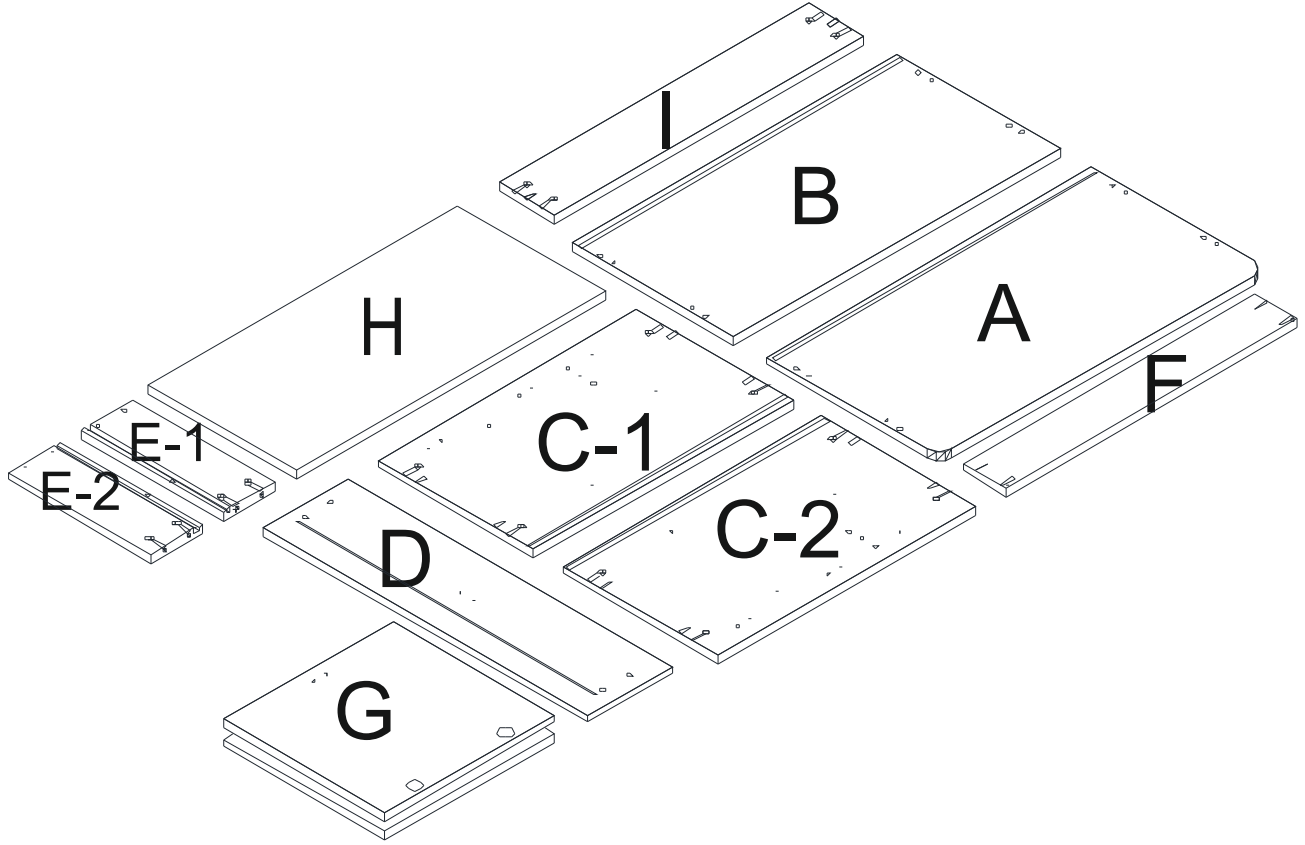

MONTAJ İÇİN GEREKLİ ALET ÖNERİLERİ: Şarjlı matkap, Yıldız başlı tornavida, Çekiç

- A: ÜST TABLA**
- B: ALT TABLA**
- C: SAĞ-SOL YAN TABLA**
- D: ÇEKMECE ÖN**
- E: ÇEKMECE YANLAR**
- F: ÇEKMECE ARKA**
- G: KAPAK**
- H: SEYYAR RAF**
- I: ARA KLAPA**

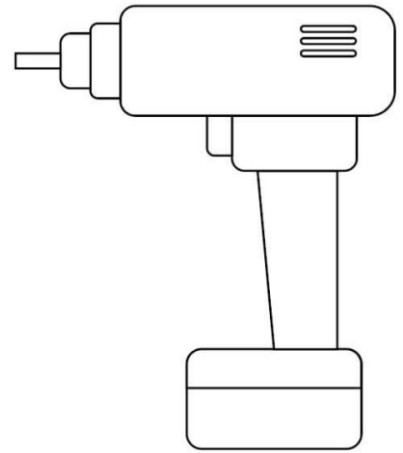
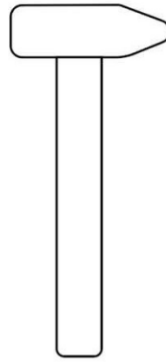

MONTAJ HAZIRLIK: MALZEME POŞET İÇERİĞİ

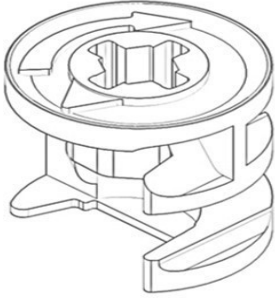

V01

16 ADET MİNİFİX
GÖVDE

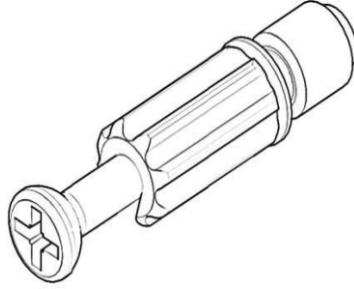

V02

16 ADET MİNİFİX
MİL

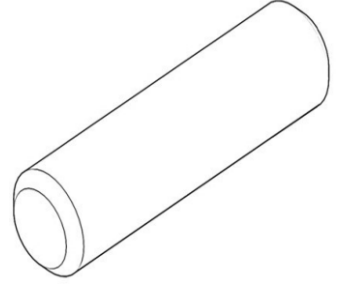

V03

10 ADET PLASTİK
SİYAH KAVELA

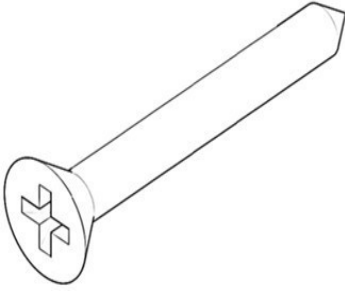

V04

4 ADET
KABİN VİDASI

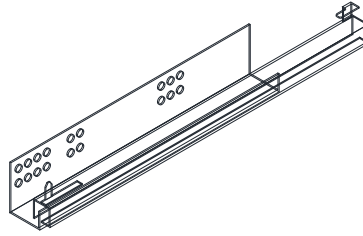

V05

1 TK
35 CM FRENLİ RAY

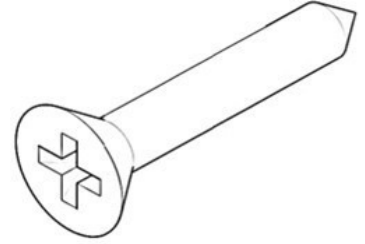

V06

28 ADET
3,5*18 VİDA

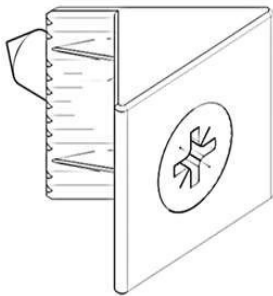

V07

5 ADET
ARKALIK SIKIŞTIRMA

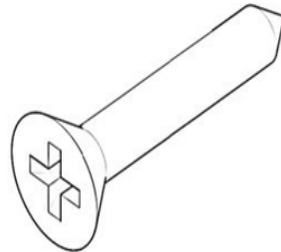

V08

7 ADET
3,5*25 ARKALIK VİDASI

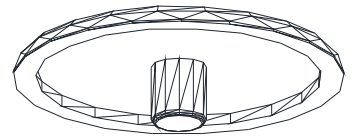

V09

16 ADET
MİNİFİX TIPASI

MONTAJ HAZIRLIK: MALZEME POŞET İÇERİĞİ

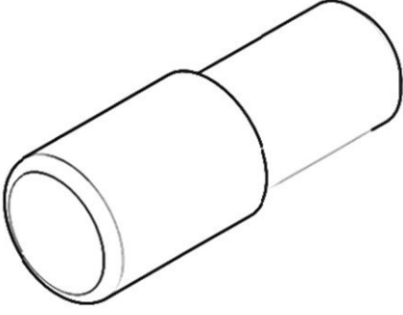

V10

4 ADET
RAF PİMİ

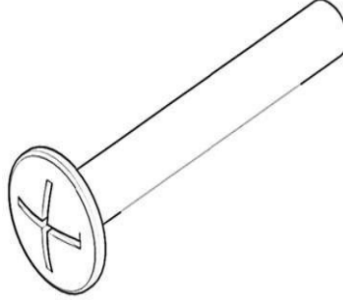

V11

8 ADET
6x25 YSB VİDA

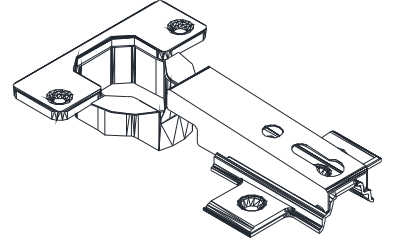

V12

4 ADET FRENLİ
DÜZ MENTEŞE

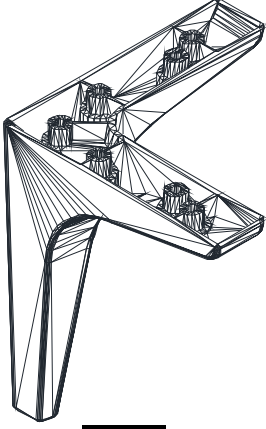

V13

4 ADET
19 CM MODA AYAK

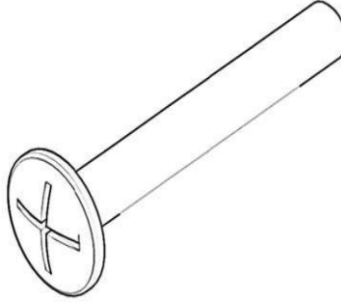

V14

6 ADET
4X22 KULP VİDASI

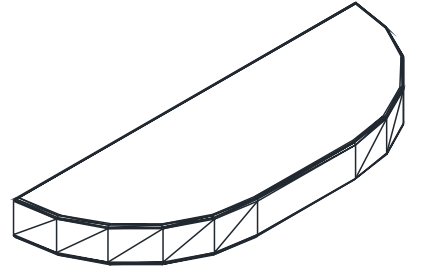

3 ADET
ETİR SİYAH KULP

MONTAJ AŞAMALARI - 1

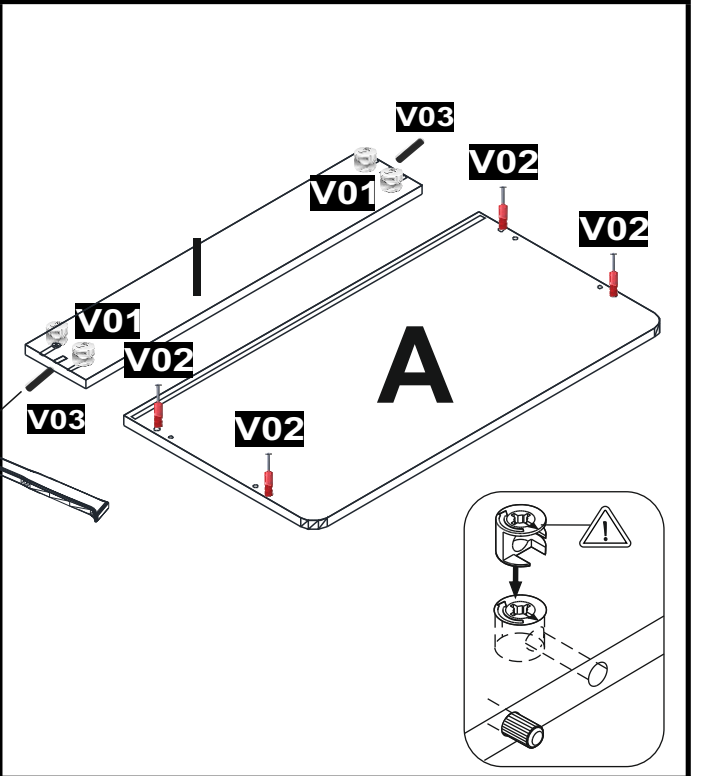
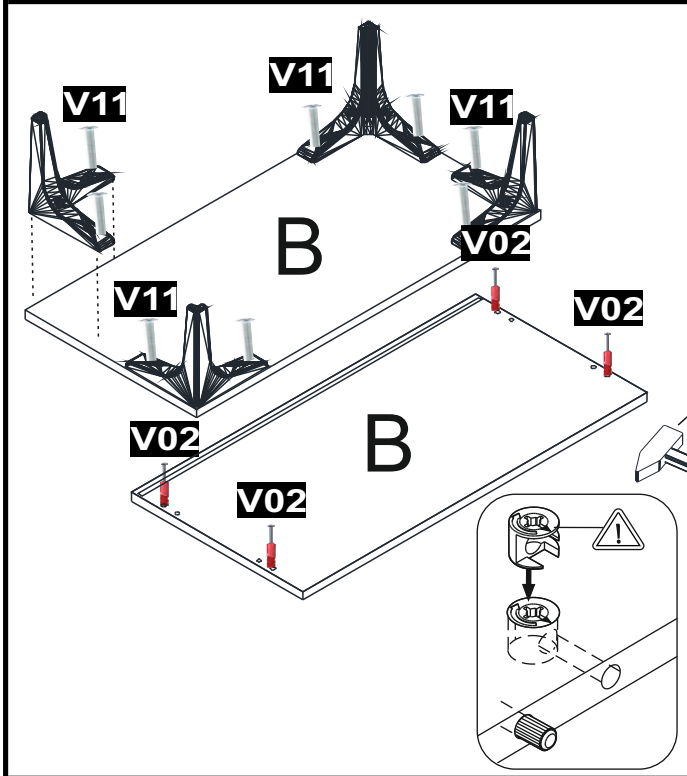

B PARÇASINDA (ALT TABLA) BULUNAN DELİKLERE ŞEKİLDE GÖRÜLDÜĞÜ GİBİ **V11** KODLU MALZEMELERİ TAKINIZ. DAHA SONRA TERS ÇEVİREREK **V02** MALZEMELERİ TORNAVİDA YARDIMI İLE TAKINIZ

A, I PARÇALARIN (ÜST TABLA) BULUNAN DELİKLERE ŞEKİLDE GÖRÜLDÜĞÜ GİBİ **V01 - V02** KODLU MALZEMELERİ TAKINIZ.

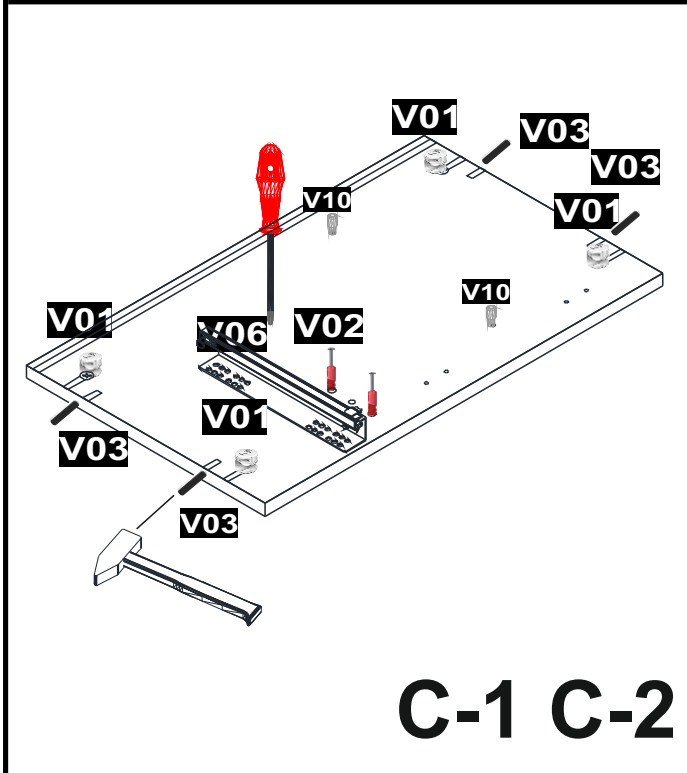

C-1 C-2

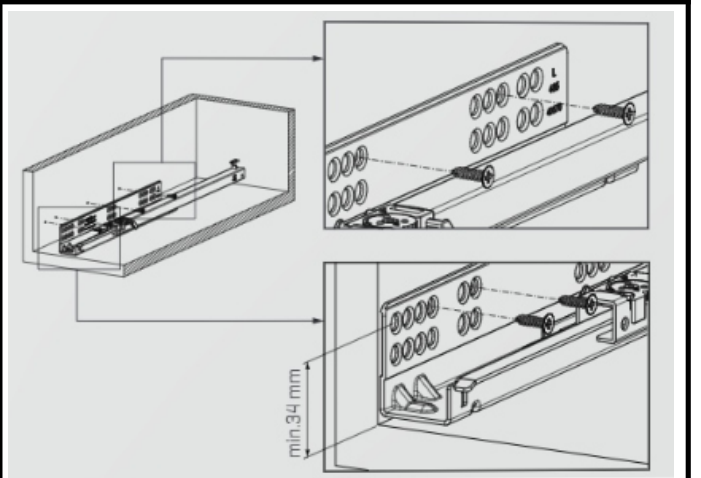

260 mm

285-310-335
360-385-410 mm



C-1 VE **C-2** PARÇALARI (SAĞ-SOL YAN TABLALAR) ÜZERİNDE BULUNAN DELİKLERE **V01, V02, V03, V10** KODLU MALZEMELERİ TAKINIZ. ARDINDAN YAN TABLA ÜZERİNDE BULUNAN VİDA İZLERİNDEN **V06** VİDALAR İLE RAYLARI

V05 KODLU MALZEME (FRENLİ RAY) BAĞLANTI KLAVUZU.

MONTAJ AŞAMALARI - 2

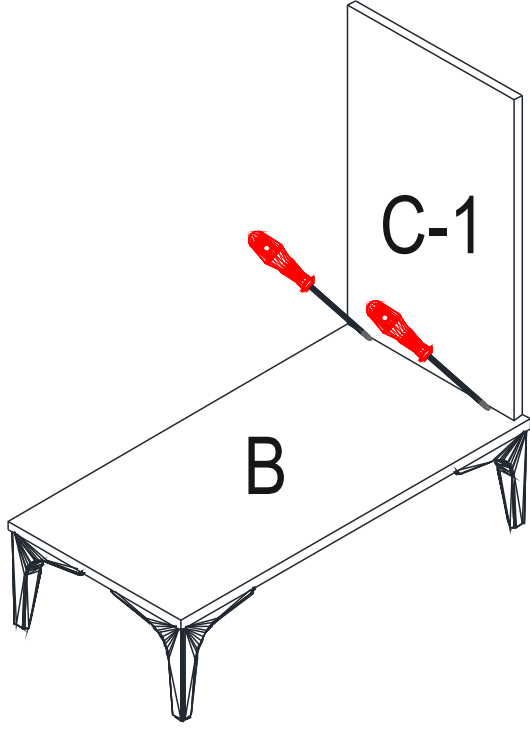

1 AŞAMA ŞEKİLDE GÖRÜLDÜĞÜ GİBİ **B VE C-1** MODÜL SIRALAMASI İLE BAŞLAYINIZ.

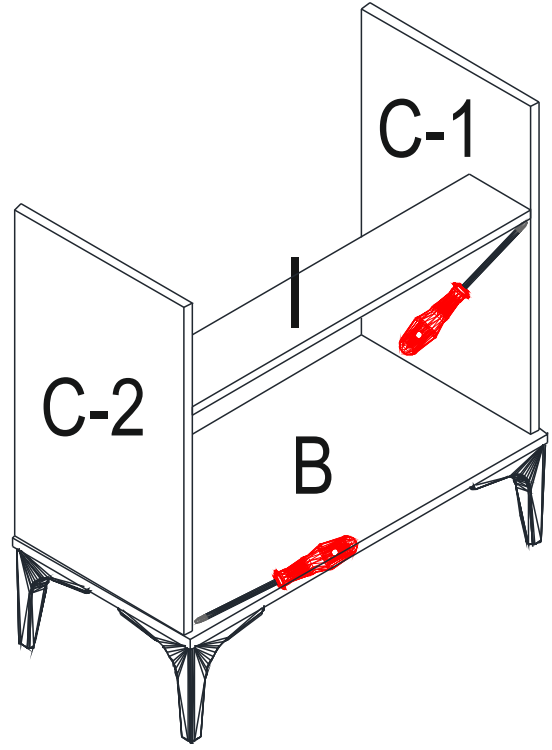

2 AŞAMA ŞEKİLDE GÖRÜLDÜĞÜ GİBİ **I VE C-2** MODÜL SIRALAMASI İLE DEVAM EDİNİZ.

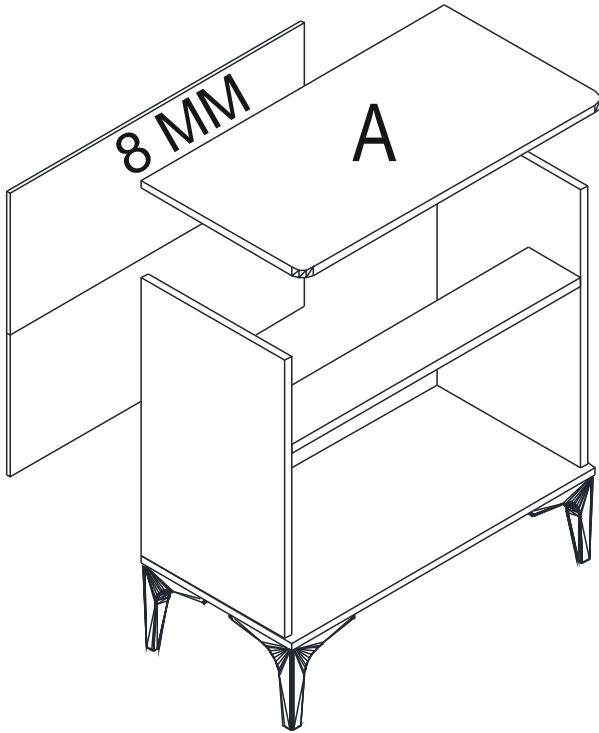

3 AŞAMA İSE ÖNCE 8 MM ARKALIKLARI TAKINIZ DAHA SONRA **A** KODLU ÜSTABLAYI TAKINIZ.

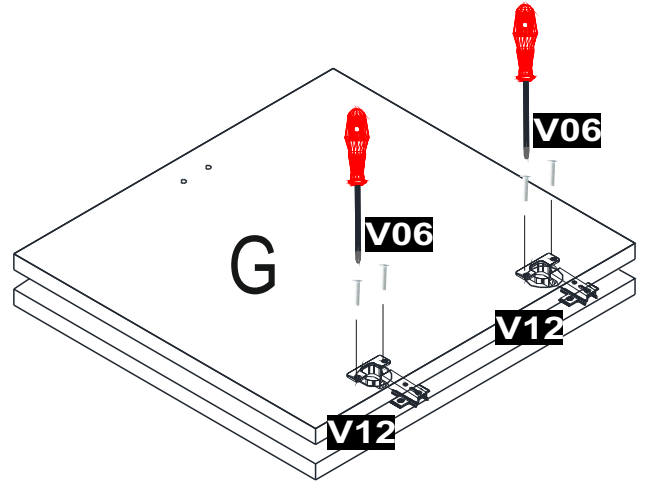

G PARÇALARIN (SAĞ SOL KAPAK) ŞEKİLDE GÖRÜLDÜĞÜ GİBİ **V06,V12** KODLU MALZEMELERİ TAKINIZ.

MONTAJ AŞAMALARI - 3

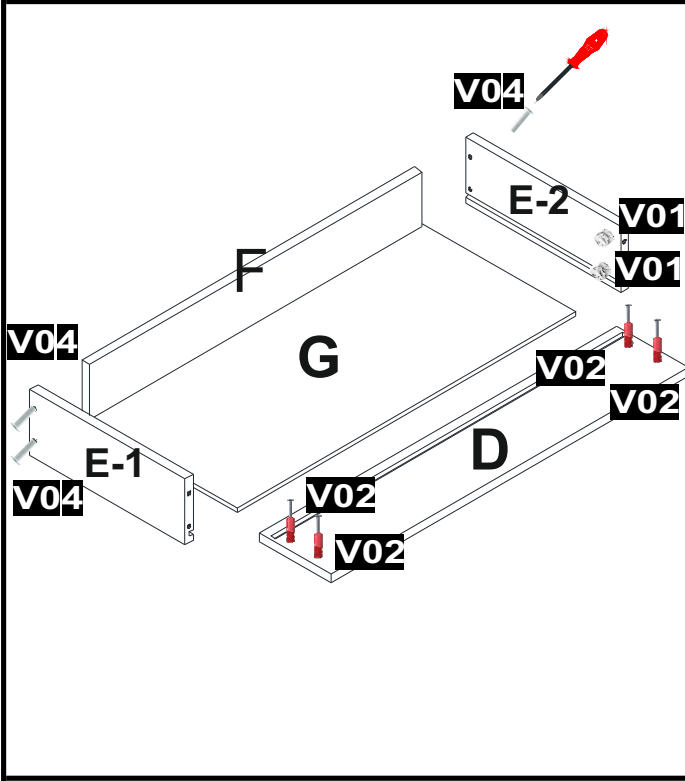

ŞEKİLDE GÖRÜLDÜĞÜ GİBİ **D** PARÇASINA **V02** KODLU MALZEMEYİ TAKINIZ. ARDINDAN **E-1 VE E-2** PARÇALARINI **D** PARÇASINA TAKINIZ. DAHA SONRA KANALLARDAN **G** PARÇASINI GEÇİRİNİZ. SON OLARAK **F** PARÇASINI **V04** KODLU MALZEMELER İLE BİRLEŞTİRİNİZ.

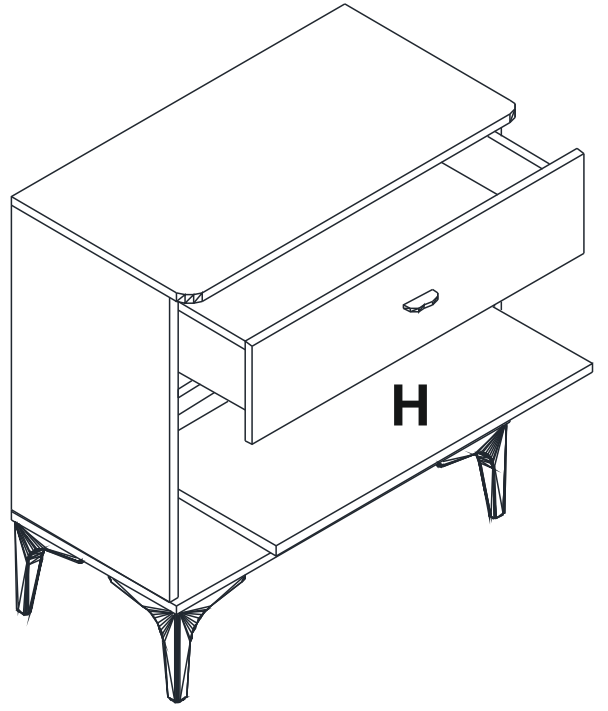

. ÇEKMECE KUTUSU OLUŞTURULDUKTAN SONRA RAY PİMLERİ ALT GÖRSELDE 1. ŞEKİLDE GÖSTERİLEN DELİKLERE DENK GELECEK ŞEKİLDE 2. RESİM TUTUŞ POZİSYONUNDA RAYLARA YERLEŞTİRİNİZ VE ALT KISIMDAKİ PİMLERİ KİLİTLEYİNİZ.

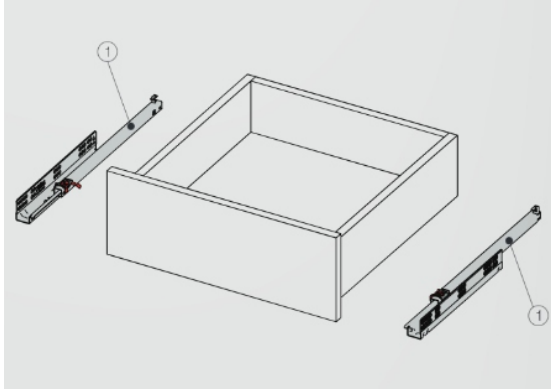
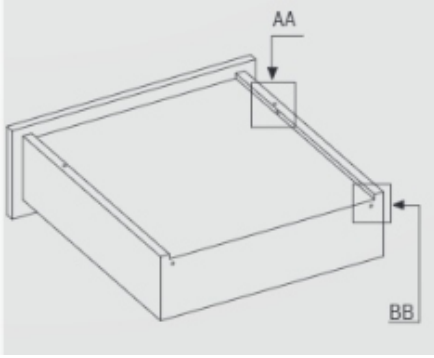

. ÇEKMECE KUTULARI OLUŞTURULDUKTAN SONRA RAY PİMLERİ 1. ŞEKİLDE GÖSTERİLEN DELİKLERE DENK GELECEK ŞEKİLDE 2. RESİM TUTUŞ POZİSYONUNDA RAYLARA YERLEŞTİRİNİZ VE ALT KISIMDAKİ PİMLERİ KİLİTLEYİNİZ.

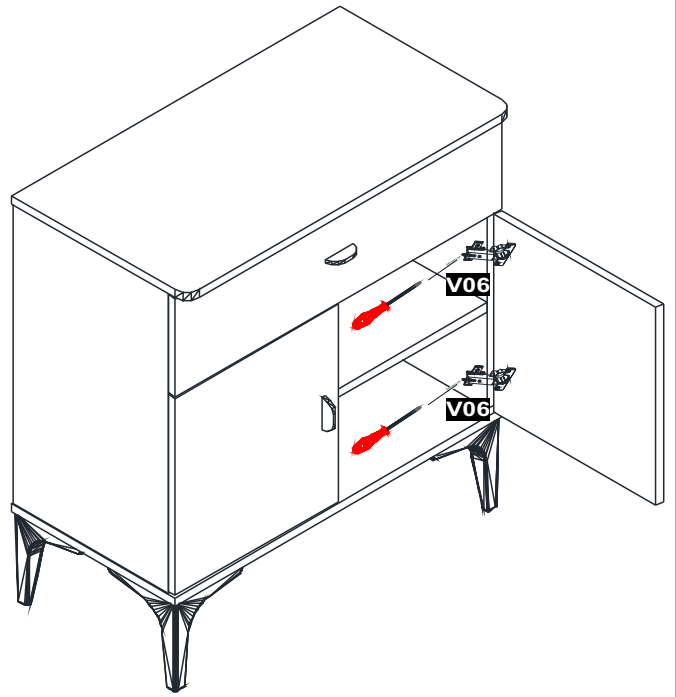

SON OLARAK DOLAP KAPAKLARINI YAN TABLA VE DİKME ÜZERİNDE BULUNAN VİDA İZLERİ REFERANS ALINARAK ŞARJLI MATKAP YARDIMIYLA VİDALAYINIZ.